



Management Card Contact & RS232 / Serial

Installation manual

EATON

EATON

INTRODUCTION

The Management Card Contact & RS232/Serial offers two types of interfaces via a DB9 connector:

- Dry contacts (contact mode)
- RS232 serial interface (RS232 mode)

All UPSs from EATON equipped with a Minislot can be connected to a number of electrical-management applications. Jumpers are used to select the interface (contacts or RS232).

APPLICATIONS

Contact mode (factory setting)

- In this mode, the card provides a simple way to remote UPS information to an alarm system, PLC or computer system via dry contacts (relay). The transmitted information is load powered, load on bypass, load on battery, load on utility, battery fault and low battery.
- A UPS power off function activated by an external contact or voltage level is also proposed. It is available only in contact mode.
- Equipped with an IBM iSeries (66033) or Windows (66047) cable available from EATON, the card offers direct communication with the power-management system of the servers supplied by the UPS and can thus provide protection (shutdown) on reception of one of the information signals. Configuration of the various systems is presented in the documents supplied with the cable. For this application, use the **Config2** setting on the card.

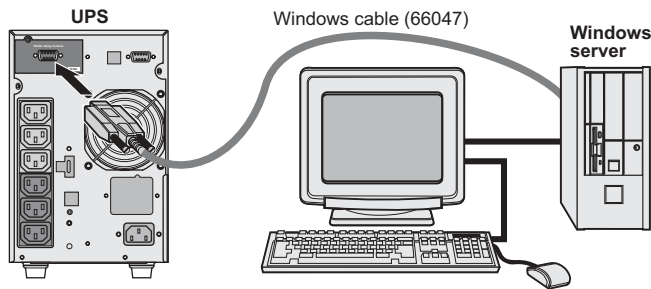

RS232 mode

- In this mode, the card offers an RS232 interface for connection to a PC or to a UPS Control display unit. Connection to a PC requires the RS232 UPS Communication Cable (66049). The cable is not supplied with the card. Once connected the protection software can be installed and used immediately.
- The **Windows™** Plug&Play function is managed by the card.
- The cable and the display are available from EATON.

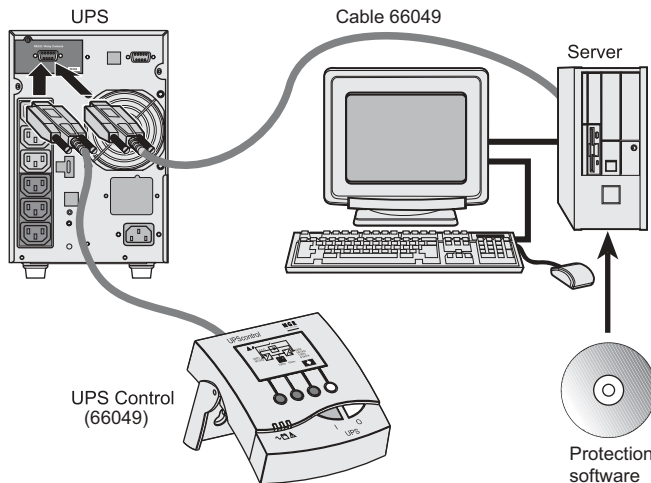

UNPACKING AND CHECKS

- One Management Card Contact & RS232/Serial
- One installation manual (34003907)

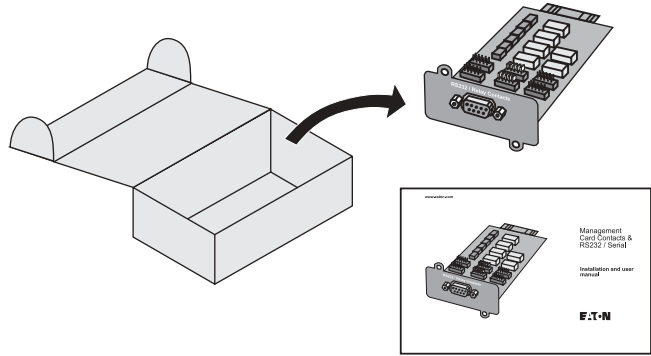

OVERVIEW

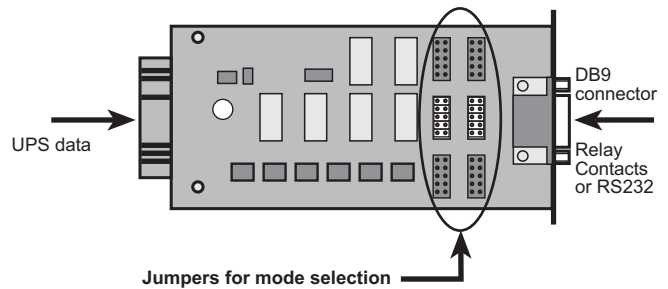

CONTACT MODE CONFIGURATION

- In this mode, the contact (relay) is closed between the common (pin 5) and the pin transmitting the signal (pin 2, 4, 6, 7, 8, 9) when UPS information is active or true.
- When the card is not supplied, all the contacts between pin 5 and the other pins are open, except the contact between pin 4 and pin 5, which remains closed.
- Three configurations are available in this mode, for three types of UPS power off. The diagram below shows, for each configuration, the jumper settings, the various contacts (card not supplied) and the external wiring for the power off function. The UPS shuts off if the contact position is the opposite of that shown.

Config1: UPS power off if contact opens	Config2: UPS power off depending on voltage level (factory setting)	Config3: UPS power off if contact closes

DB9 CONNECTOR PINOUTS

No.	Function	Description
1	Not used	
2*	Battery fault (Config 2) UPS power off (Config 1 or 3)	Config 2: a battery fault occurred. Config 1 or 3: UPS power off by contact.
3	UPS power off (Config 2) Not used (Config 1 or 3)	Config 2: UPS power off by voltage level.
4	Load on utility**	The load is protected. The UPS supplies the load using utility power (not from the battery).
5	Common	Config 2: volt-free pin. Config 1 or 3: pin connected to GND.
6	Load on automatic bypass***	The load is not protected. The UPS supplies the load using utility power. If utility power fails, the load will not be supplied.
7	Low battery	The battery has dropped below the preset warning level (depending on UPS setup). If the voltage level continues to drop, the UPS will no longer be capable of supplying power to the load.
8	UPS ON, load powered	The UPS is operational and can supply power to the load, whether utility power is available or not, whether the UPS is on the bypass or not.
9	Load on battery **	The load is protected. The UPS supplies the load from the battery (not using utility power).

* The function of this pin varies, depending on the configuration. The Battery fault information is available only in Config 2.

** Load on utility and Load on battery are complementary signals. They cannot be activated simultaneously.

*** Not available on line-interactive UPS. No manual bypass.

RS232 MODE CONFIGURATION

▶ In this mode, only one configuration is possible.

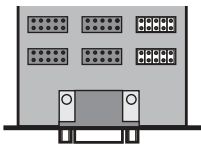

DB9 CONNECTOR PINOUTS

No.	Function	Description
2	TD	Transmit data (output)
3	RD	Receive data (input)
5	GND	Ground
6	RTS	Plug-&-Play (input)
1, 4, 7, 8, 9	Not used	

INSTALLATION

The **Contact & RS232/Serial Management Card** can be installed on a running UPS from EATON compatible with this card. It is not necessary to shutoff the UPS, disconnect the load or restart the UPS.

- ▶ Remove the plastic cover of the Minislot.
- ▶ Insert and secure the card with the screws.

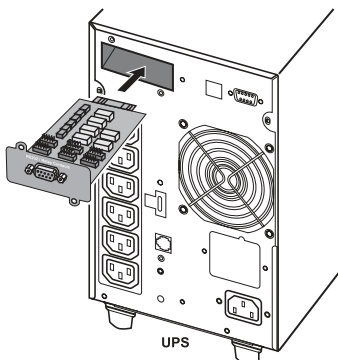

TECHNICAL CHARACTERISTICS

Physical characteristics	
Dimensions (W x H x D)	66 x 42 x 132 mm
Weight	70 g
RoHS	100% compatible
Storage	
Storage temperature range	-10°C to 70°C
Ambient conditions	
Operating temperature range	0°C to 40°C
Relative humidity	90% RH max. without condensation
Performance	
Card	
Supply voltage	5 V +/- 5%
Supply current (all relays activated)	150 mA max.
Supply current (all relays deactivated)	15 mA max.
Relay contacts (output)	
Double insulation (optocoupler)	> 4000V DC
Max. contact resistance	75 mOhm
Max. switching voltage	<40 V AC or <50 V DC
Max. switching current	1 A max (e.g. for five contacts, 200 mA max for each contact.)
Max. switching power	40 W
Min. switching capacity	10 µA 10 mV DC
Service life (min. number of operating cycles)	10 ⁵
Max. recommended distance	20 meters
UPS power off (input)	
Single insulation (optocoupler)	> 4000V DC
Max. acceptable external contact resistance (including cable, Config 1 or 3)	20 Ohm
Min. & max. voltage (Config 2)	+3 V DC to +50 V DC
Min. input current (Config 2)	500 µA
Max. input current (Config 2)	60 mA
Min. impulse duration	>100 ms
Reverse voltage	Diode protection
Max. recommended distance	20 meters
Note. The UPS does not take into account the shutdown time required by any protected applications once the shutoff order has been requested. Power at the UPS outputs is interrupted immediately (<100 ms).	
Serial interface	Compliant with EIA-232E specifications

SAFETY INSTRUCTIONS



The relay contacts and the card inputs are galvanically isolated from the UPS. It is strictly forbidden to apply a voltage greater than 40 V AC or 50 V DC to the contacts. Disregard for this restriction may endanger human life, damage equipment and cancel the manufacturer warranty.

ELECTROMAGNETIC COMPATIBILITY

When correctly installed and used in accordance with manufacturer instructions, the card complies with the following standards:

- ▶ ITE (Information Technology Equipment) safety: IEC/EN 60950-1 2002
- ▶ EMC: EN 61000-6-2 (2002), EN 61000-6-3 (2002), IEC/EN 62040-2 (2002) In compliance with European directives:
- ▶ Low voltage: 73/23/EEC and 93/68/EEC.
- ▶ EMC: 89/336/EEC and 93/68/EEC.

Federal Communication Commission (FCC) statement

This equipment has been tested and found to comply with the limits for a **Class B** digital device, pursuant to part 15 of the FCC rules. These limits are designed to provide reasonable protection against harmful interference when the equipment is operated in a commercial environment.

WEB SITE

The information presented in this manual is also available in other languages at download.mgeops.com for MGE Office Protection Systems products, www.powerware.com for Powerware products.